

# RIO1S

## Relay / Input / Output Transformer-Balanced Module

### Features

- Transformer-isolated, balanced line-level input
- 600-ohm or 10k-ohm jumper-selectable input impedance
- Transformer-isolated, balanced line-level output
- 8-ohm, 750mW output
- Input and output level controls
- Relay responds to selectable priority level
- External control of priority muting
- N.O. or N.C. relay contacts
- Input can be muted from higher priority modules, with signal fade back
- Output can activate with relay priority level
- Screw terminal strips
- RJ11 connection with line output and dedicated N.O. relay contact

# Module Installation

1. Turn off all power to the unit.
2. Make all necessary jumper selections.
3. Position module in front of any desired **module bay opening**, making sure that the module is right-side up.
4. Slide module onto card guide rails. Make sure that both the top and bottom guides are engaged.
5. Push the module into the bay until the faceplate contacts the unit's chassis.
6. Use the two screws included to secure the module to the unit.

**WARNING:**

*Turn off power to unit and make all jumper selections before installing module in unit.*

**Note:**

This module may include a break-away tab as pictured below. If present, remove this tab to install module in input module bays.

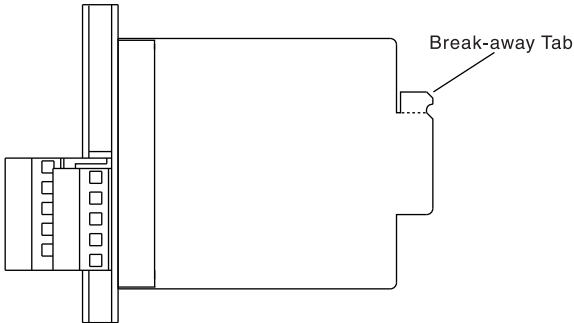

# Controls and Connectors

## Gain (Input)

Provides control over the level of input signal.

## Signal Output

Transformer-balanced, low-impedance (8-ohm) line-level output.

## Mute + / Mute -

Provides access to the mute bus priority system. Allows external equipment to directly control the internal mute buses.

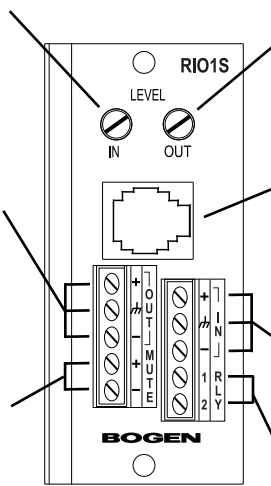

## Level (Output)

Provides control over the level of output signal.

## RJ11 Connection

This connector contains the output signal and a set of normally open relay contacts. It acts similar to telephone systems' page ports and facilitates interfacing to paging systems with override capabilities (PCM2000, ZPM3).

## Input Signal

Transformer-balanced, line-level input.

## Prioritized Relay Output

Provides access to the priority controlled relay contacts. Can be jumper configured as normally open (N.O.) or normally closed (N.C.).

# Jumper Selections

## Impedance Selector

This module can be set for two different input impedances. When connecting to a 600-ohm source, it is desirable to have a 600-ohm matching input impedance. For typical source equipment, use 10k-ohm setting.

## Input Muting

This module's input can remain continuously active or be muted by other modules. When muting is enabled, the input is permanently set to the lowest priority level. When disabled, the input will not respond to any priority signal and will remain active continuously.

## Input Bus Assignment

This module can be set to operate so that the input signal can be sent to the main unit's A bus, B bus, or both buses. Bus selection pertains to M-Class use only. Power Vector has only one bus. Set jumpers to Both for Power Vector use.

## External Mute Priority Level

Determines what priority level the system will see when looking at the external control. Selecting Level 1 will result in the external device becoming the highest priority mute and silencing all lower priority modules. Likewise for all other lower settings except for priority Level 4, which is not applicable since modules with this level can only respond to mute signals. Priority Level 4 modules cannot send mute signals.

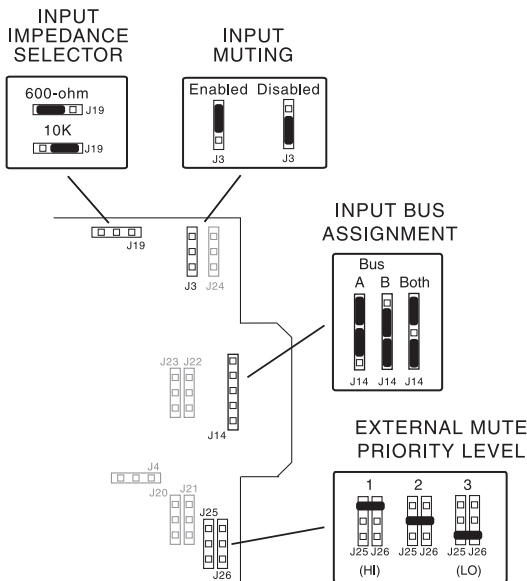

# Jumper Selections, cont.

## Relay Priority Level

The relay setting determines what priority level and above will cause the relay to energize. Since this module's relay must receive a mute signal from a higher priority module to change states, it is only possible to use the three lower priority levels (2, 3, 4). Priority Level 1 (highest) is not applicable.

## Output Gating

The output signal can be available continuously or available only when the relay priority level setting has been met or exceeded. When set to ACTIVE, it provides continuous signal output. When set to GATE, it provides output based on priority level.

## Relay Contacts

This module's screw terminal relay contacts can be set for normally open (N.O.) or normally closed (N.C.) operation.

## Output Bus Assignment

The output signal can be taken from the module's A bus, B bus, or the unit's MIX bus. On some Bogen amplifier products, the A and B buses may be tied together.

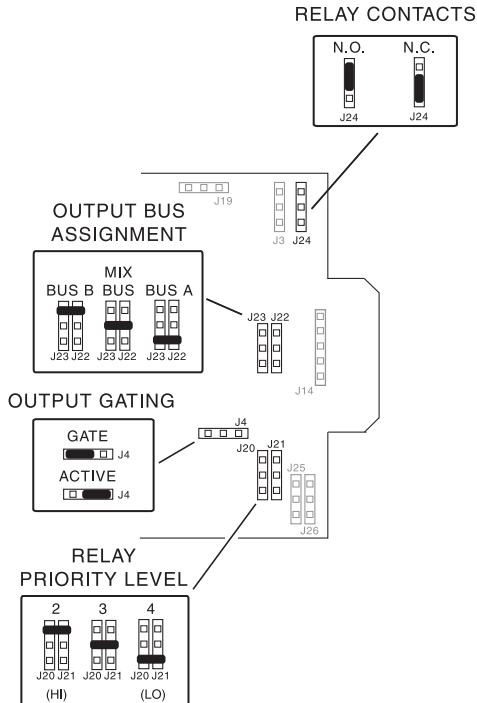

# Input Wiring

## Balanced Connection

Use this wiring when the external equipment supplies a balanced, 3-wire signal.

Connect the shield wire of the external signal to the ground terminal of the external equipment and to the ground terminal of the RIO1S. If the "+" signal lead can be identified, connect it to the plus "+" terminal of the RIO1S. If the external equipment polarity cannot be identified, connect either of the hot leads to the plus "+" terminal. Connect the remaining lead to the minus "-" terminal of the RIO1S.

**Note:** If polarity of the output signal versus the input signal is important, it may be necessary to reverse input lead connections.

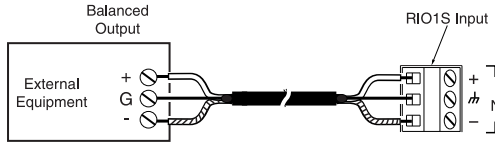

## Unbalanced Connection

When the external device provides only an unbalanced connection (signal and ground), the RIO1S module should be wired with the "-" terminal shorted to ground. The unbalanced signal's shield wire is connected to the input module's ground and the signal hot wire is connected to the "+" terminal. Since unbalanced connections do not provide the same amount of noise immunity that a balanced connection does, the connection distances should be made as short as possible.

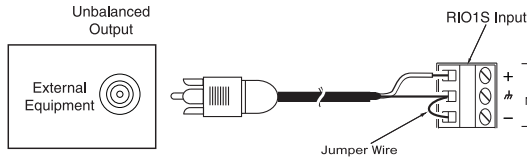

# Output Wiring

## Balanced Connection

Use this wiring when the external equipment requires a balanced, 3-wire signal.

Connect the shield wire to the ground terminal of the external equipment and to the ground terminal of the RIO1S. If the "+" signal lead from the external equipment can be identified, connect it to the plus "+" terminal of the RIO1S. If the external equipment polarity cannot be identified, connect either of the hot leads to the plus "+" terminal. Connect the remaining lead to the minus "-" terminal of the RIO1S.

**Note:** If polarity of the output signal versus the input signal is important, it may be necessary to reverse input lead connections.

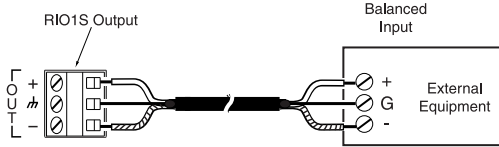

## Unbalanced Connection

When the external device provides only an unbalanced connection (signal and ground), the RIO1S module should be wired with the "-" terminal shorted to ground. The unbalanced signal's shield wire is connected to the input module's ground and the signal hot wire is connected to the "+" terminal. Since unbalanced connections do not provide the same amount of noise immunity that a balanced connection does, the connection distances should be made as short as possible.

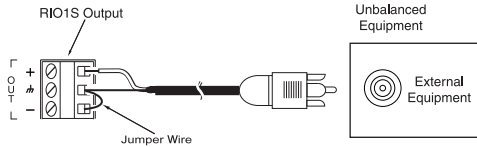

# Speaker Output Wiring

## 8Ω Output

The RIO1S output is capable of driving an 8Ω speaker load. Available power is up to 750mW. When connecting a speaker, be sure to connect the module's "+" and "-" to the speaker's "+" and "-", respectively.

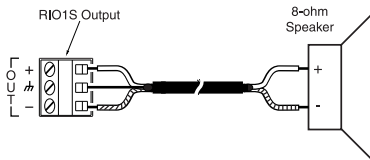

# Block Diagram

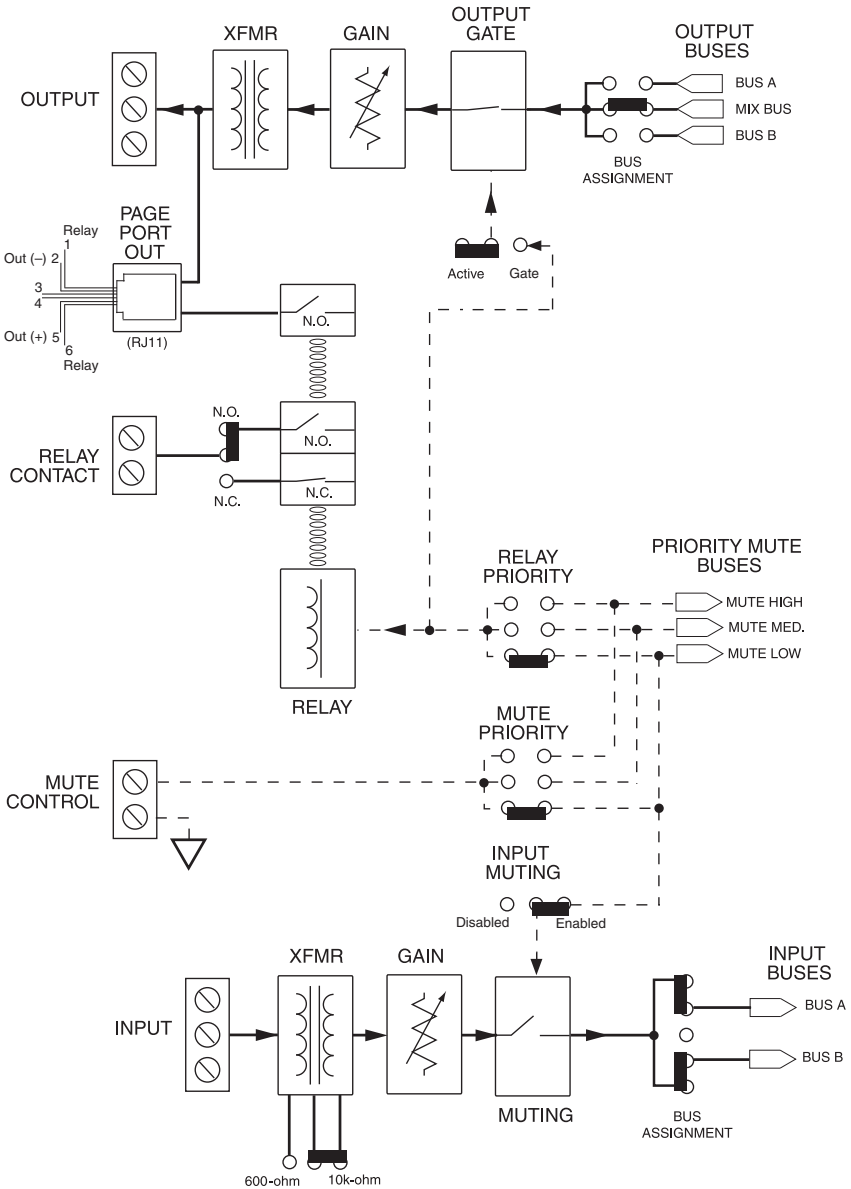

**BOGEN<sup>®</sup>**  
**COMMUNICATIONS, INC.**

50 Spring Street, Ramsey, NJ 07446, U.S.A.

201-934-8500; Fax: 201-934-9832

www.bogen.com